

Strip Staple Set Brush

Worksheet [R. 01.2015]

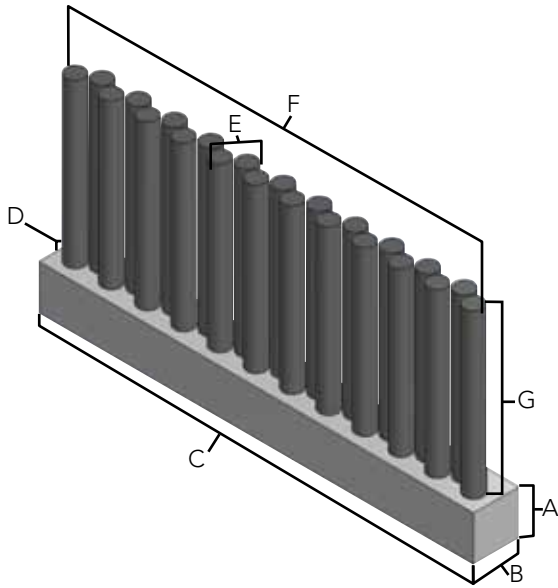

Contact Name: _____

Company Name: _____

Phone: _____

Fax: _____

Email: _____

BLOCK:

Material: HDPE Polypropylene Wood Other _____

A. Height (Thickness): _____ B. Width _____ C. Length _____

BRUSH PATTERN:

D. Distance between block edge and center of 1st tuft: _____

Same on both ends? Yes No

E. Width of brush face area: _____ F. Length of brush face area: _____

Size of hole (tuft diameter):

.118 in/3.0mm .157 in/4.0mm .217 in/5.5mm

.256 in/6.5mm .315 in/8.0mm

Number of holes (WxL) : _____ x _____

Face Density: Heavy Medium Light

Hole Pattern: Straight Staggered



straight



staggered

FILAMENT/TRIM:

G. Filament trim height: _____

Filament diameter: _____

Material: Nylon 6.0 Polypropylene Horsehair Other: _____

Filament Shape: Level Crimped Trim Shape: Flat Beveled



level



crimped



flat



beveled

Specifications

Quantity to release per order: _____

Are there drawings or sample available for reference? Yes No

APPLICATION -Please be sure to identify any special factors that should be considered such as FDA approved material, temperature, moisture, chemical exposure, etc.:
